

---

## Town of Cassian - Ordinance

---

### 3.06

#### AMENDED REQUIREMENTS FOR TOWN ROAD CONSTRUCTION

##### Section A

The Town Board of Supervisors of the Town of Cassian, Oneida County, Wisconsin, do hereby find, determine and ordain, that in order to promote public safety and general welfare, it is necessary that certain requirements and standards be established and followed in the creation, improvement and repair of public roadways in the Town of Cassian.

This ordinance is not intended repeal, abrogate, annul, or interfere with any existing state or federal highway regulations governing construction of public roadways.

##### Section B

In order to clarify this ordinance, the following definitions apply:

**Right -of-Way-** the land or property to be acquired or used for hwy purposes.

**Roadway -** construction area of road.

**Roadbed -** the graded portion of a roadway prepared as the foundation for the pavement structure and shoulders.

**Surface Grade -** the traveled portion of the roadway.

**Grade -** the rate of ascent or descent of a road. **Section C**

The following are the standards set by the Town Board of Supervisors for the construction of public roads in compliance with sound engineering practices, general construction and safety. Approval by the Town Board of Supervisors shall be obtained prior to any deviation from these standards.

Right-of-Way (ROW)<sup>1</sup>

- . The minimum width for any roadway ROW shall not be less than 66 feet.
2. The minimum radius for a cul-de-sac shall be 75 feet, unless otherwise agreed upon by the Town Board of Supervisors.
3. At all bend points in the ROW, where the tangent deflection angle is over 45 degrees or larger, the tangent shall be connected with a curve having a

---

## Town of Cassian - Ordinance

---

minimum length of 300 feet as measured along the centerline. This shall

not apply to road intersections.

### Roadway

1. Clearing and grubbing of all trees, stumps, and brush shall be extended five feet beyond the slope intercept of all cut and fill sections.
2. No trees, stumps, brush, or large rocks shall be disposed of within the

Roadway. Disposal of large rocks may be allowed in roadway embankments with prior approval by the Town Board of Supervisors.

3. All excavated organic materials shall be disposed of either by placing in

Six-inch maximum depth layers on the roadway embankments in cut and fill sections, or by disposing off the roadway.

### Roadbed

1. All marsh, swamp, muck and peat material shall be removed from the area of the proposed roadbed to ensure a stable foundation for the roadbed fill.
2. The roadbed fill shall be free of large rocks (greater than 6 inches), muck, peat and other organic material.
3. Fill material shall consist of sand and gravel and placed in 6 inch lifts and compacted to prevent differential settlement.
4. Drainage structures of the proper size shall be installed to ensure proper drainage and to prevent the flooding of the roadbed or adjacent property.

### Surface Course

1. Crushed aggregate for the base course shall be placed to a compacted depth of 6 inches but may be reduced to a depth of 4 inches upon approval of Town Board and shall conform to the requirements of gradation # 2 of Sec. 304 of the Wisconsin Standard Specifications for Road and Bridge Construction (1996). The crushed aggregate base course shall be placed to minimum width of 28 feet. Cul-du-sacs with a 75-foot radius shall have a 28-foot crushed aggregate base course as shown in exhibit A.

---

## Town of Cassian - Ordinance

---

minimum length of 300 feet as measured along the centerline. This shall

not apply to road intersections.

### Roadway

1. Clearing and grubbing of all trees, stumps, and brush shall be extended five feet beyond the slope intercept of all cut and fill sections.
2. No trees, stumps, brush, or large rocks shall be disposed of within the

Roadway. Disposal of large rocks may be allowed in roadway embankments with prior approval by the Town Board of Supervisors.

3. All excavated organic materials shall be disposed of either by placing in

Six-inch maximum depth layers on the roadway embankments in cut and fill sections, or by disposing off the roadway.

### Roadbed

1. All marsh, swamp, muck and peat material shall be removed from the area of the proposed roadbed to ensure a stable foundation for the roadbed fill.
2. The roadbed fill shall be free of large rocks (greater than 6 inches), muck, peat and other organic material.
3. Fill material shall consist of sand and gravel and placed in 6 inch lifts and compacted to prevent differential settlement.
4. Drainage structures of the proper size shall be installed to ensure proper drainage and to prevent the flooding of the roadbed or adjacent property.

### Surface Course

1. Crushed aggregate for the base course shall be placed to a compacted depth of 6 inches but may be reduced to a depth of 4 inches upon approval of Town Board and shall conform to the requirements of gradation # 2 of Sec. 304 of the Wisconsin Standard Specifications for Road and Bridge Construction (1996). The crushed aggregate base course shall be placed to minimum width of 28 feet. Cul-du-sacs with a 75-foot radius shall have a 28-foot crushed aggregate base course as shown in exhibit A.

## **Town of Cassian - Ordinance**

---

2. All work done for the Township under the heading of hot mix asphalt paving, shall be done in accordance with the State of Wisconsin Standard Specifications for Road and Bridge Construction, 2010 Edition (or most current edition), according to Sections 450 through 460.2.7 and including the special provisions. The bituminous material used in the mix shall be a type A.C. with a PG graded asphalt designation of 58-28. The asphalt content in the mix shall be within the range of 5.4% to 6.4%. The aggregates used in the mix shall be gradation 12.5 mm. The mix produced shall be a Type E 0.3 according to Section 407 of the

supplemental specifications. The minimum width shall be 22 feet. Cul-de-sacs having a 75- foot radius shall be paved as shown in exhibit (A).

3. Bituminous pavement shall not be constructed between October 15 and May 15 without the prior approval of the Town Board or their engineering representative.
4. The roadway shall conform to the attached typical cross section (exhibit B).

### **Inspection**

1. Each phase of the roadway construction (rough grading, gravel base, bituminous paving) must be approved by the Town Board or their engineering representatives prior to the commencement of the next phase of construction.

### **Section D**

Upon completion of a roadway, the Town Board of Supervisors shall

conduct a final inspection. If during the inspection, deficiencies are noted in the construction, such deficiencies must be corrected prior to approval of payment. Should it become necessary for the Town Board of Supervisors to engage the services of an engineering firm to verify compliance with the road specifications hereinbefore set forth, the road builder will be responsible for the cost of those services, and payment will be deducted from the final payment for services rendered.

### **Section E**

Where any section of this ordinance or part thereof is amended, void, or superseded thereby, the remaining sections not so specifically amended, void, or superseded shall remain in effect.

Note: Attached hereto as "Exhibit A", "Exhibit B" and Exhibit C are the

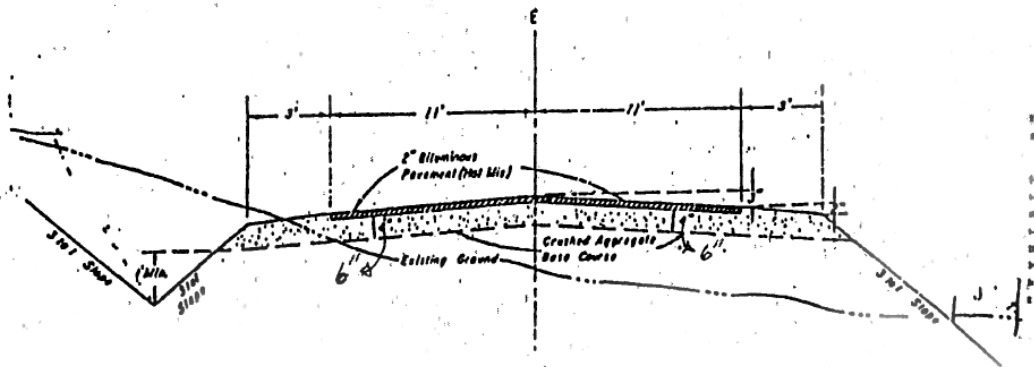
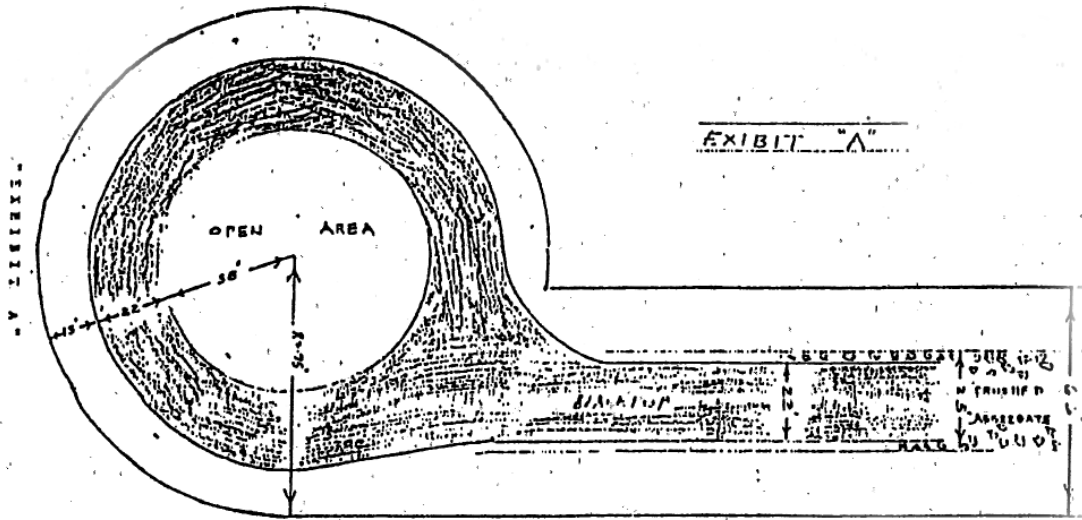

TYPICAL CROSS-SECTION

EXHIBIT "A"

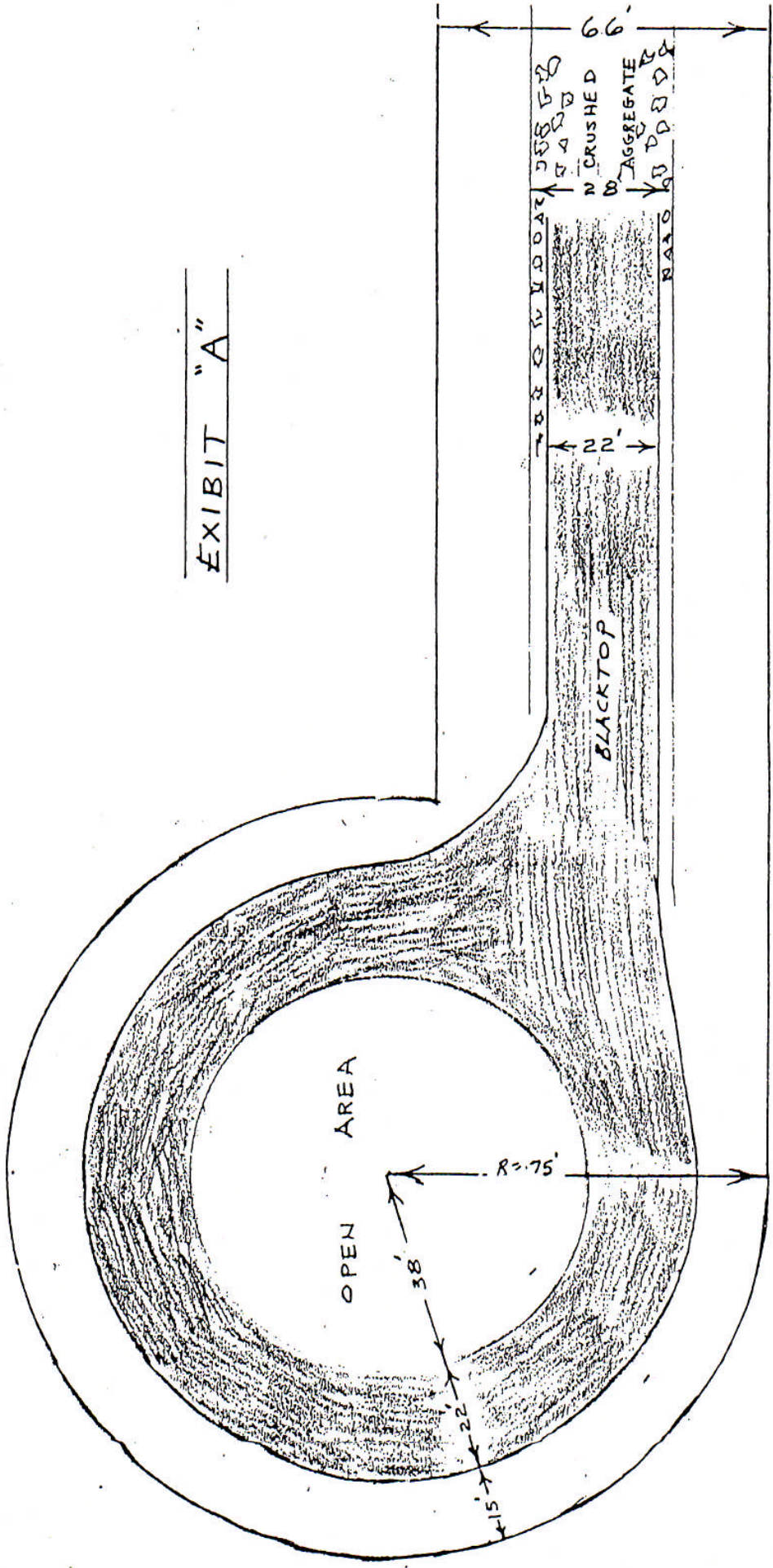

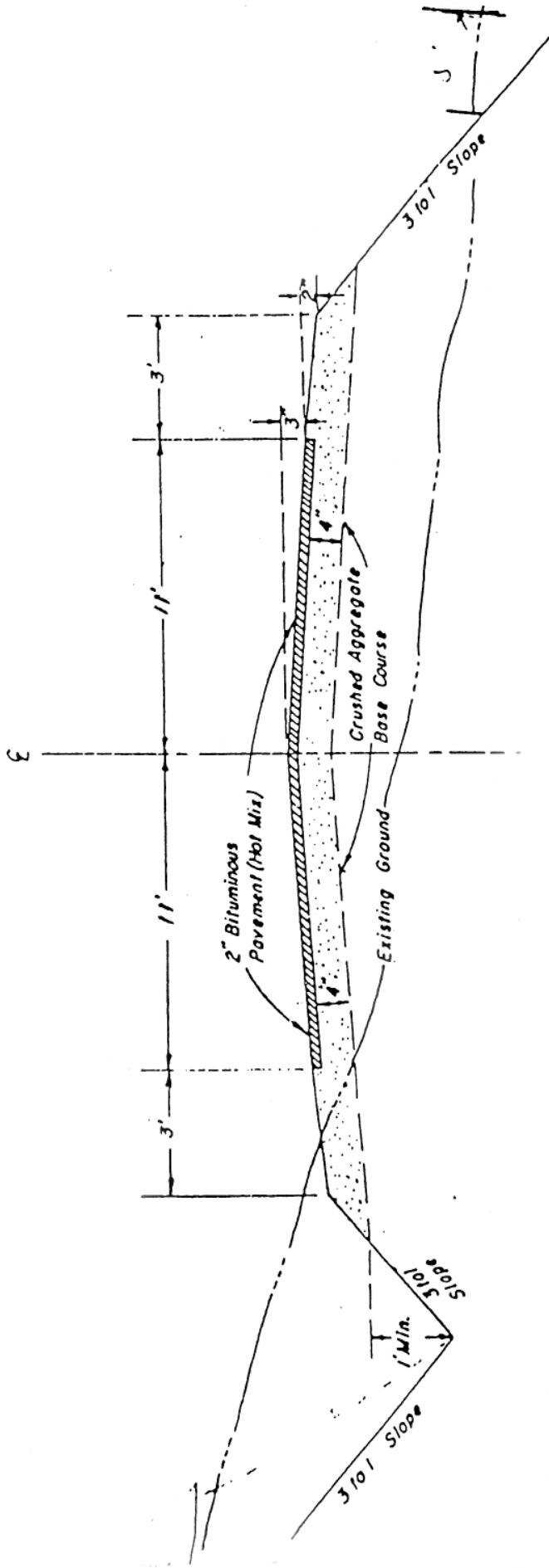

TYPICAL CROSS-SECTION

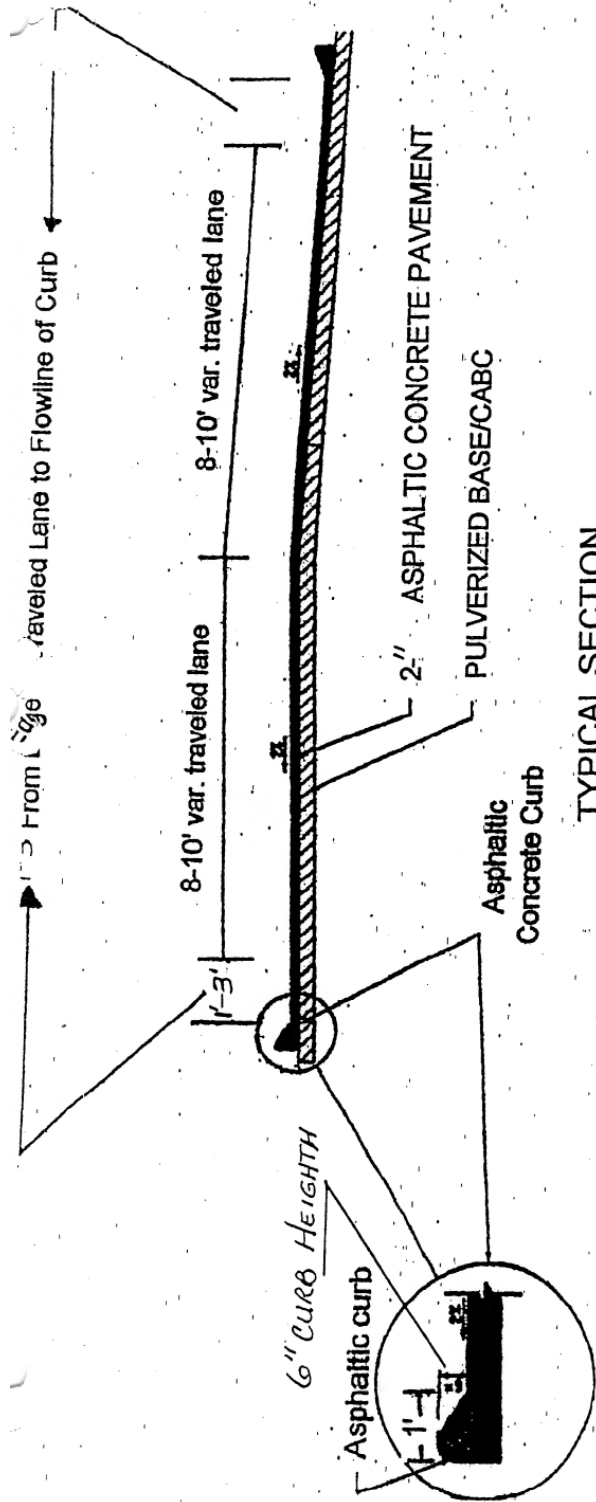

TYPICAL SECTION

NOTE: NO TAPER AT THE BEGINNING AND END OF CURB

1'-3" From Edge of Traveled Way to Flowline of Curb

Edge of Traveled Way

CENTERLINE OF ROADWAY

PLAN VIEW

Exhibit C